

PRODUCT SPECIFICATION SHEET

12kg MyProXL Electric Vented Dryer



TE1220E



Dimension:

W686 x D822 x H1098mm

Finish:

Stainless Steel

Features:

- Top durability with 15.000+ cycle lifetime
- Easy to clean, heavy duty lint screen
- Faster and more efficient drying process
- Larger drying load capacity: 12 kg
- Axial airflow ensures the shortest drying time
- Extremely low energy usage

NOTE: Images, specifications and dimension correct at the time of publishing. It is advised that these details be confirmed prior to construction as no liability will be taken by Harvey Norman Commercial for any changes in specifications.

PRODUCT SPECIFICATION SHEET

12kg MyProXL Electric Vented Dryer



TE1220E

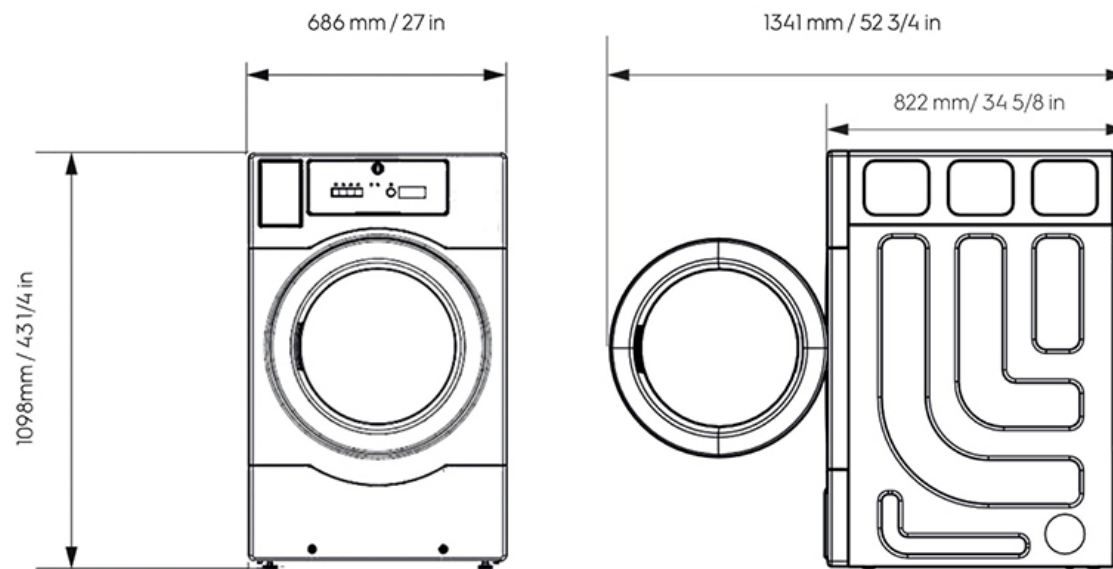

NOTE: Images, specifications and dimension correct at the time of publishing. It is advised that these details be confirmed prior to construction as no liability will be taken by Harvey Norman Commercial for any changes in specifications.