

PRODUCT SPECIFICATION SHEET

9kg Commercial Electric Clothes Dryer



LDE3TR



Dimension:

W683 x D711 x H1092mm

Finish:

White

Features:

- 9Kg per load
- Commercial construction and strength
- Whisper quite air flow system
- 3 drying cycles
- 198L drum capacity
- Time dry or Auto-dry function

NOTE: Images, specifications and dimension correct at the time of publishing. It is advised that these details be confirmed prior to construction as no liability will be taken by Harvey Norman Commercial for any changes in specifications.

PRODUCT SPECIFICATION SHEET

9kg Commercial Electric Clothes Dryer

 **Speed Queen**

LDE3TR

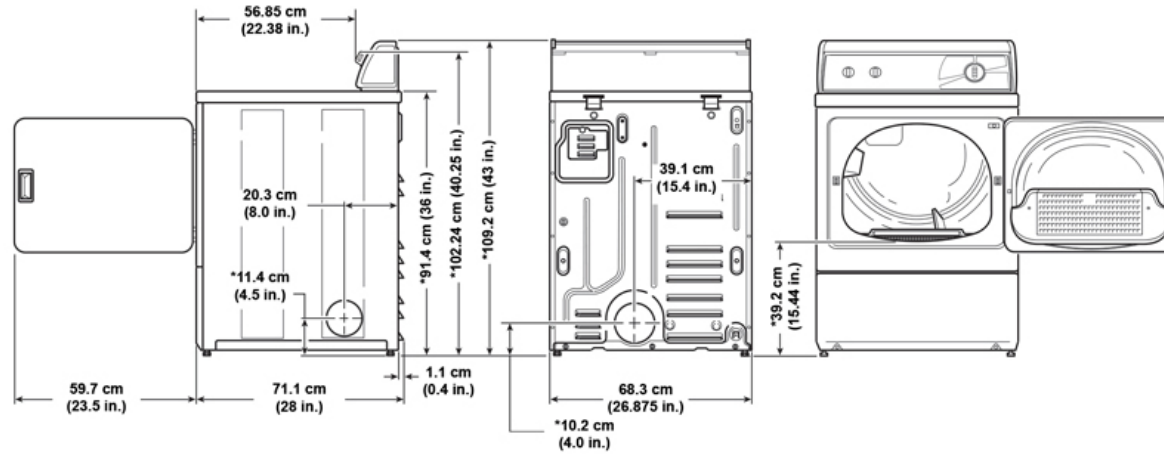

NOTE: Images, specifications and dimension correct at the time of publishing. It is advised that these details be confirmed prior to construction as no liability will be taken by Harvey Norman Commercial for any changes in specifications.