

# PRODUCT SPECIFICATION SHEET

## 800mm 700 Series Electric Range with Oven



### 7PCFE800



#### Dimension:

W800 x D700 x H900mm

#### Finish:

Stainless Steel

#### Features:

- Four burner solid plate electric cook top with electric oven
- 220 mm diameter cast iron elements
- Knobs with IPX5 water jet ingress protection rating
- AISI304 stainless steel construction
- Total power - 3 phase, 16.4kw

NOTE: Images, specifications and dimension correct at the time of publishing. It is advised that these details be confirmed prior to construction as no liability will be taken by Harvey Norman Commercial for any changes in specifications.

# PRODUCT SPECIFICATION SHEET

## 800mm 700 Series Electric Range with Oven

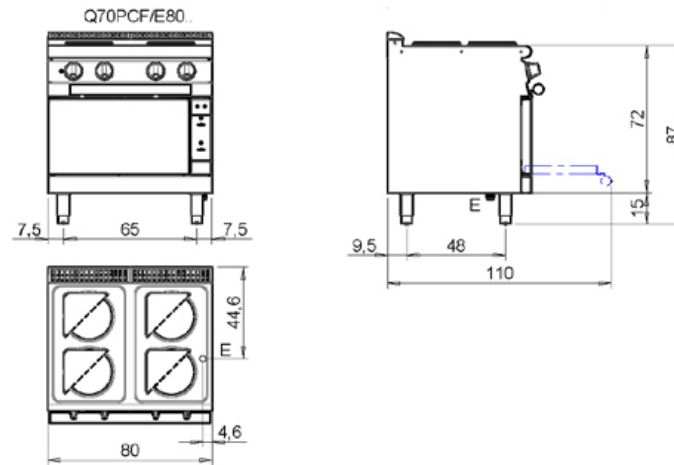

NOTE: Images, specifications and dimension correct at the time of publishing. It is advised that these details be confirmed prior to construction as no liability will be taken by Harvey Norman Commercial for any changes in specifications.