

PRODUCT SPECIFICATION SHEET

21 Litre Commercial Microwave



CM1051T

Bonn

Dimension:

W497 x D428 x H325mm

Finish:

Stainless Steel

Features:

- 1000W
- Ceramic base
- Toughened glass
- Heavy duty latches & hinges
- 10amp
- High performance magnetron
- Programmable touchpad 20 preset options
- Stackable

NOTE: Images, specifications and dimension correct at the time of publishing. It is advised that these details be confirmed prior to construction as no liability will be taken by Harvey Norman Commercial for any changes in specifications.

PRODUCT SPECIFICATION SHEET

21 Litre Commercial Microwave

Bonn
CM1051T

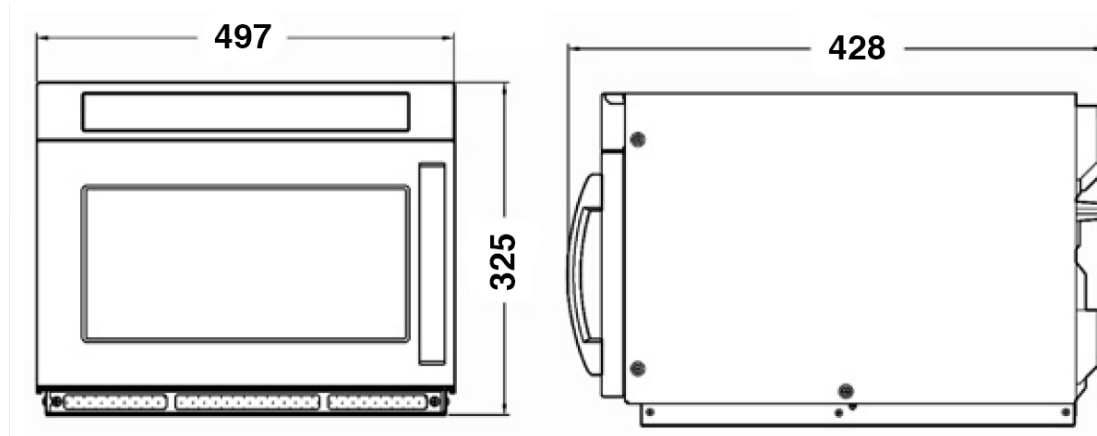

NOTE: Images, specifications and dimension correct at the time of publishing. It is advised that these details be confirmed prior to construction as no liability will be taken by Harvey Norman Commercial for any changes in specifications.